

ACCU COLOR 250™



User Instructions

American DJ®
4295 Charter Street
Los Angeles CA. 90058
www.americandj.com

American DJ®

Accu Color 250™

Table of Contents

Unpacking.....	3
Introduction.....	3
Customer Support.....	3
Safety Precautions.....	4
Handling Precautions.....	5
Discharge Lamp Warnings.....	5
Registration.....	6
Features.....	6
Controls and Functions.....	7
Set-Up.....	10
System Menu.....	13
Editing Program.....	25
Operating Modes.....	28
Fuse and Lamp Replacement.....	31
DMX Traits.....	32
Optional Gobo.....	34
Cleaning.....	35
Trouble Shooting.....	36
Warranty.....	37
Specifications.....	39

Unpacking: Thank you for purchasing the Accu Color 250™ by American DJ®. Every Accu Color 250™ has been thoroughly tested and has been shipped in perfect operating condition. Carefully check the shipping carton for damage that may have occurred during shipping. If the carton appears to be damaged, carefully inspect your fixture for any damage and be sure all equipment necessary to operate the unit has arrived intact. In the event damage has been found or parts are missing, please contact our toll free customer support number for further instructions. Please do not return this unit to your dealer without contacting customer support first.

Introduction: The Accu Color 250™ is a eight channel, moving head, intelligent DMX fixture. The fixture can operate in three different operating modes; stand alone, sound-active, or in a Master/Slave configuration. The Accu Color 250™ comes with several built in programs and is best used in multiples of four. When used as a stand alone unit or when used in multiples linked in a master/slave configuration. *For best results use fog or special effects smoke to enhance the beams projections.*

During the initial start-up or use of this product a light smoke or smell may arise from the unit. This is a normal process and is cause by the heat associated with the lamp.

Customer Support: American DJ® provides a toll free customer support line, to provide help and to answer any question should you encounter problems during your set up or initial operation. You may also visit us on the web at www.americandj.com for any comments or suggestions. Service Hours are Monday through Friday 9:00 a.m. to 5:00 p.m. Pacific Standard Time.

Voice: (800) 322-6337

Fax: (323) 582-2610

E-mail: support@americandj.com

To purchase parts online visit <http://parts.americandj.com>

Warning! To prevent or reduce the risk of electrical shock or fire, do not expose this unit to rain or moisture.

Warning! *This may cause severe eye damage. Avoid looking directly into the light source at all times!*

For Your Own Personal Safety, Please Read and Understand This Manual Completely Before You Attempt To Install Or Operate This Unit!

- To reduce the risk of electrical shock or fire, do not expose this unit rain or moisture
- Do not spill water or other liquids into or on to your unit.
- Be sure that the local power outlet match that of the required voltage for your unit.
- Do not attempt to operate this unit if the power cord has been frayed or broken.
- Do not attempt to remove or break off the ground prong from the electrical cord. This prong is used to reduce the risk of electrical shock and fire in case of an internal short.
- Disconnect from main power before making any type of connection.
- Do not remove the cover under any conditions. There are no user serviceable parts inside.
- Never operate this unit when it's cover is removed.
- Always be sure to mount this unit in an area that will allow proper ventilation. Allow about 6" (15cm) between this device and a wall.
- Do not attempt to operate this unit, if it becomes damaged.
- This unit is intended for indoor use only, use of this product outdoors voids all warranties.
- Always mount this unit in safe and stable matter.
- Power-supply cords should be routed so that they are not likely to be walked on or pinched by items placed upon or against them, paying particular attention to cords at plugs, convenience receptacles, and the point where they exit from the appliance.
- Cleaning -The fixture should be cleaned only as recommended by the manufacturer. See page 38 for cleaning details.
- Heat -This fixture should be situated away from heat sources such as radiators, heat registers, stoves, or other appliances (including amplifiers) that produce heat.
- The fixture should be serviced by qualified service personnel when:
 - A. Objects have fallen, or liquid has been spilled into the appliance.
 - B. The appliance has been exposed to rain or water.
 - C. The appliance does not appear to operate normally or exhibits a marked change in performance.

Caution! There are no user serviceable parts inside this unit. Do not attempt any repairs yourself, doing so will void your manufacturer's warranty. In the unlikely event your unit may require service please contact American DJ®.

During operation the housing may become extremely hot. Avoid touching the unit with bare hands while in use.

American DJ® will not accept any liability for any resulting damages caused by the non-observance of this manual or any unauthorized modification to this unit.

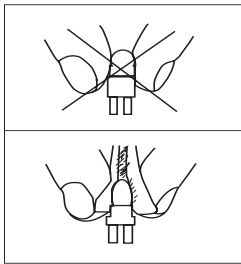

This fixture is fitted with a discharge lamp which is highly susceptible to damage if improperly handled. Never touch the lamp with your bare fingers as the oil from your hands will shorten lamp life. Also, never move the fixture until the lamps have had ample time to cool. Remember, lamps are not covered under warranty conditions.

This unit emits intense UV radiation which is harmful to the eyes and skin. The intense luminance of the lamp can cause severe damage to the retina. Never operate this unit without its covers, these covers have been specially designed to shield against UV radiation.

Epileptic Warning: *Those suffering from epilepsy should avoid looking directly into the lamp at all times.*

Avoid switching the fixture on and off repeatedly in short intervals as this will reduce lamp life and intensity.

To achieve the intensity associated with discharge lamps, these lamps use gas sealed in a high pressure environment to emit a brilliant output. Due to the high pressure involved with the construction of the lamp, the lamp may explode during prolonged extensive use. This risk is increased with age, added care is encouraged when dealing with older lamps. Extreme caution should be used when operating this or any fixture fitted with a gas discharge lamp. Never open this unit while in use.

To optimize the performance of this product, please read these operating instructions carefully to familiarize yourself with the basic operations of this unit. These instructions contain important safety information regarding the use and maintenance of this unit. Please keep this manual with the unit, for future reference.

The Accu Color 250™ carries a one year limited warranty. Please fill out the enclosed warranty card to validate your purchase. All returned service items whether under warranty or not, must be freight pre-paid and accompany a return authorization (R.A.) number. The R.A. number must be clearly written on the outside of the return package. A brief description of the problem as well as the R.A. number must also be written down on a piece of paper and included in the shipping carton. If the unit is under warranty, you must provide a copy of your proof of purchase invoice. You may obtain a R.A. number by contacting our customer support team on our toll free customer support number. All packages returned to the service department not displaying a R.A. number on the outside of the package will be returned to the shipper at the shipper's cost.

- Micro-Stepping Motors for Smooth Color Transitions
- DMX-512 Protocol Compatible (Uses Three DMX Channels)
- 8 Colors, Plus White - With Rainbow
- Removable Static Gobo,
- Optional 30° Beam Angle Lens **(Not Included)**
- 3 Operating Modes - Master/Slave; Stand Alone; Sound Active
- Internal Microphone
- ZB-MSD250/2 Discharge Lamp, 230v/250w
- Edit and Save Scenes into the Memory
- Manual Focus Lens
- Variable Strobe (1-12 fps)
- Digital Display for Address and Function Setting
- Mini/C Input Jack for Blackout Function (Mini/C Controller Not Included)

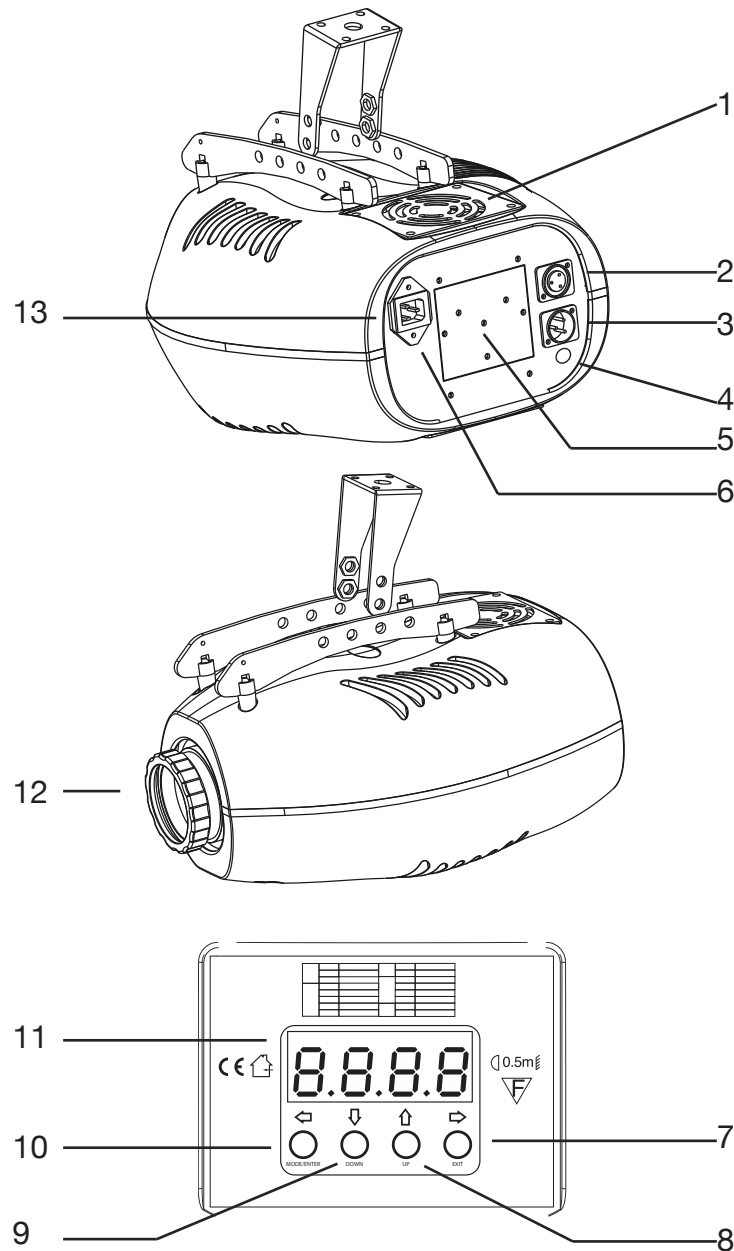

1. Cooling Fan - This unit is equipped with three high velocity variable fans to aid in the cooling process. These fans are designed to vary their velocity at different operating temperatures, to provide better cooling when the unit reached higher operating temperatures associated with long usage. Be sure to never obstruct the cooling fans during normal usage. Also, be sure to keep the vents clean at all times. A blocked or malfunctioning cooling system may shorten lamp life and unit reliability.

2. XLR Output Jack - This jack is used to transmit the incoming DMX signal to another DMX fixture, or transmit a Master/Slave signal to the next Accu Color 250™ in the chain. For best results in DMX or Master/Slave mode terminate this jack if it is the last unit in the chain. See “Terminator” on page 11.

3. XLR DMX Input Jack - This jack is used to receive an incoming DMX signal or Master/Slave signal.

4. MINI/C Controller Jack - This jack is for use with the optional MINI/C controller only. This controller is used to control the blackout function. Do not attempt to connect an audio signal to this jack, this will damage the PC board and void your manufactures warranty!

5. Lamp Assembly and Access Plate - This plate accesses the lamp socket assembly. The unit includes a spring mounted ZB-MSD250/2 250w discharge lamp. Be sure to only replace with same type lamp. After replacing a lamp be sure the lamp is centered in the reflector. See page 32 for details on installing and optimizing replacement lamps. Never operate this unit with the lamp exposed, this lamp emits strong UV radiation.

6. Power Cord Inlet - This unit is equipped with a removable I.E.C. power cord. Be sure to only use the power cord included with the unit, this cord is designed to match the electrical requirements of the unit. Other cords may cause the unit to overheat or malfunction. Voltage may vary from venue to venue, when connecting this unit to a power supply be sure to connect to a matching power outlet. Never use this fixture if the ground prong has been removed or broken off. The ground prong is designed to reduce the risk of fire or electrical shock in the event the unit suffers from an internal short.

- 7. Exit Button** - This button is used to exit menus.
- 8. Up Button** - This button is used to scroll forward when navigating through the system menu.
- 9. Down Button** - This button is used to scroll backwards when navigating through the system menu
- 10. Mode/Enter Button** - This button is used to select and confirm a function when working in the system menu.
- 11. Digital Display** - This display shows the menu and operating functions that you can choose from.
- 12. Lens Assembly** - This high quality lens is a fully focusing. Focus the lens by manually turning the lens in a clockwise or counter-clockwise direction until the desired effect is achieved.
- 13. Fuse Holder** - This housing stores a 8 amp (4 amp 220v) GMA protective fuse. Never defeat the fuse, the fuse is designed to protect the electronics in the event of severe power fluctuations. Always be sure to replace the fuse with an exact match as the one being replaced, unless otherwise told to do so by an authorized American DJ® service technician.

Power Supply: Before plugging your unit in, be sure the source voltage in your area matches the required voltage for your American DJ® Accu Color 250.™ The American DJ® Accu Color 250™ is available in a 120v and 220v version. Because line voltage may vary from venue to venue, you should be sure your unit voltage matches the wall outlet voltage before attempting to operate you fixture. Also be sure to only use the included I.E.C. power cable supplied with the unit, this cable matches the voltage and current requirements of the unit.

DMX-512: *DMX is short for Digital Multiplex. This is a universal protocol used by most lighting and controller manufactures as a form of communication between intelligent fixtures and controllers. A DMX controller sends DMX data instructions from the controller to the fixture. DMX data is sent as serial data that travels from fixture to fixture via the DATA “IN” and DATA “OUT” XLR terminals located on all DMX fixtures (most controllers only have a DATA “OUT” terminal).*

DMX Linking: DMX is a language allowing all makes and models of different manufactures to be linked together and operate from a single controller, as long as all fixtures and the controller are DMX compliant. *To ensure proper DMX data transmission, when using several DMX fixtures try to use the shortest cable path possible. The order in which fixtures are connected in a DMX line does not influence the DMX addressing. For example; a fixture assigned a DMX address of 1 may be placed anywhere in a DMX line, at the beginning, at the end, or anywhere in the middle. Therefore, the first fixture controlled by the controller could be the last fixture in the chain. When a fixture is assigned a DMX address of 1, the DMX controller knows to send DATA assigned to address 1 to that unit, no matter where it is located in the DMX chain.*

Data Cable (DMX Cable) Requirements (For DMX and Master/Slave Operation): The Accu Color 250™ can be controlled via DMX-512 protocol. The Accu Color 250™ is a three channel DMX unit. The DMX address is set electronically using the controls on the side panel of the unit. Your unit and your DMX controller require a standard 3-pin XLR connector for data input and data output (Figure



Figure 1

1). If you are making your own cables, be sure to use standard two conductor shielded cable (This cable may be purchased at almost all professional sound and lighting stores). Your cables should be made with a male and female XLR connector on either end of the cable. Also remember that DMX cable must be daisy chained and cannot be split.

Notice: Be sure to follow figures two and three when making your own cables. Do not use the ground lug on the XLR connector. Do not connect the cable's shield conductor to the ground lug or allow the shield conductor to come in contact with the XLR's outer casing. Grounding the shield could cause a short circuit and erratic behavior.

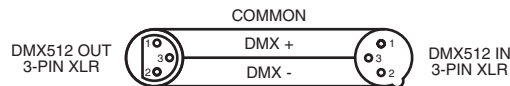

Figure 2

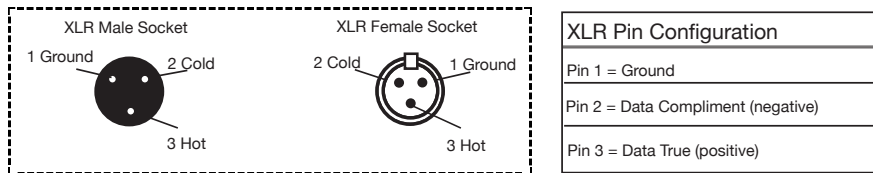
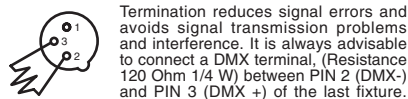

Figure 3

Special Note: Line Termination. When longer runs of cable are used, you may need to use a terminator on the last unit to avoid erratic behavior. A terminator is a 90-120 ohm 1/4 watt resistor which is connected between pins 2 and 3 of a male XLR connector (DATA + and DATA -). This unit is inserted in the female XLR connector of the last unit in your daisy chain to terminate the line. Using a cable terminator (ADJ part number Z-DMX/T) will decrease the possibilities of erratic behavior.



Termination reduces signal errors and avoids signal transmission problems and interference. It is always advisable to connect a DMX terminal. (Resistance 120 Ohm 1/4 W) between PIN 2 (DMX-) and PIN 3 (DMX+) of the last fixture.

Figure 4

5-Pin XLR DMX Connectors. Some manufactures use 5-pin XLR connectors for DATA transmission in place of 3-pin. 5-pin XLR fixtures may be implemented in a 3-pin XLR DMX line. When inserting standard 5-pin XLR connectors in to a 3-pin line a cable adaptor must be used, these adaptors are readily available at most electric stores. The chart below details a proper cable conversion.

3-Pin XLR to 5-Pin XLR Conversion		
Conductor	3-Pin XLR Female (Out)	5-Pin XLR Male (In)
Ground/Shield	Pin 1	Pin 1
Data Compliment (- signal)	Pin 2	Pin 2
Data True (+ signal)	Pin 3	Pin 3
Not Used		Pin 4 - Do Not Use
Not Used		Pin 5 - Do Not Use

ADDR	A001~A511		Indicate the staring DMX address A001 also is the setting for slave
TEST	T-01~T-XX		Automatically test the function
AUDI	MSTR ALON		Runs fixture as "master" for audio Runs fixture as "alone" for audio
RESE	ALL COLR SHTR	ON/OFF ON/OFF ON/OFF	Reset all motors and returns fixture to home Reset only motors for color Reset only motors for shutter and/or dimmer
TIME	LIFE LAMP CLMP	0000~9999 0000~9999 ON/OFF	Displays the total fixture running time Displays a lamps running time Clear lamp running time
DISP	VALU D ON FLIP	D-XX D-00 (DXXX) ON/OFF ON/OFF	Display the DMX512 value of each channel Display on/off This function will reverse the display 180
SPEC	SPOT DFSE VER	ON/OFF ON/OFF V1.0~V9.9	Lamp optimization Resets all the fixture functions to default Software version
EDIT	RUN STEP SCXX	ON/OFF S-01 ~ S-48 SC01 - SC30	Run your designed program Set the amount of steps in your program Scenes that can be edited in your program
		C-01 - C-03 TIME	Fixture DMX channel Time of each scene
		ON/OFF CEDT	Controller Editing

ADDRESS MENU -

A001 - A511 (Value) - This is where you set the DMX address of the unit.

TEST MENU -

T-01 - T-XX (Test) - Tests the functions of each channel. There are eight channels, but only channels 1,2,3,4, and 6 can be tested.

AUDI MENU -

MSTR (Master) - Runs the unit as master in sound active mode.

ALON (Alone) - Runs the unit stand alone, sound active mode.

RESE (RESET) MENU -

ALL - Resets all the motors in the unit.

COLR (Color) - Resets the color motors.

SHTR - Resets the shutter motors.

TIME MENU -

LIFE - Displays the fixtures total running time.

LAMP - Displays the lamp running time.

CLMP - Clears the lamp running time.

DISPLAY MENU -

VALU (DMX-512 Value) - Display the DMX-512 value of each channel.

D ON (Display On) - Turns digital display on and off.

FLIP - "Flips" the digital display 180°.

SPEC MENU -

SPOT - This provides a spot beam for better lamp optimization.

DFSE (Reset) - Resets the unit to default settings.

VER (Version) - Software version 2.2

EDIT MENU -

RUN - This will run your own custom program.

STEP (S-01 - S-48) - These are the steps slots that you write your programs into. See edit program, page 28.

SCXX (SC01 - SC30) - These are the scenes that are stored in your program. There are a total of 30 scenes.

C-01 - C-08 (Channel 1 - Channel 08) - The channels of each scene that can be edited. See page 28.

TIME (Time) - Running time of the entire program. See page 28.

EDIT - Edit program using a external controller. See page 30.

On-Board System Menu. The Accu Color 250™ comes with an easy to navigate system menu. This next section will detail the functions of each command in the system menu.

Mode/Enter Button - To access the main menu locate the MODE/ENTER button (10) on the front of the unit. Press this button to activate the system menu. Tap the UP button (8) until you reach function you wish to change. When you reach the function you wish to change tap the MODE/ENTER button. When a function is selected the menu will begin to flash, use the UP button to change the function. Once your changes are made tap the MODE/ENTER button again to lock the change in the system. To exit without making any changes tap the EXIT button (7).

ADDR MAIN MENU -

ADDR DMX Address Setting via control board -

1. Access the main menu.
2. Tap the UP button until "ADDR" is displayed, press ENTER.
4. Now the display will show "ADDR". Adjust the DMX address by pressing the UP or DOWN buttons.
5. Press MODE/ENTER to confirm.
6. Press the EXIT button to return to the main menu.

When the display is on "ADDR", you can directly press the UP or DN buttons to change the DMX start address.

TEST MAIN MENU -

TEST - This will test the functions of each channel.

1. Access the main menu.
2. Tap the UP button until "TEST" is displayed, press ENTER.
3. The display will show "T-01". You can now press the up button and test the different channels. For example: If you

press the up button until “T-03” is displayed, the unit will test the color channel, changing the color one by one and show the rainbow effect with different speeds. There are eight channels, but only channels 1,2,3,4, and 6 can be tested.

5. Press MODE/ENTER or EXIT to exit.

AUDI MAIN MENU -

MASTER Define the unit as the master, in master/slave mode-

1. Access the main menu.
2. Tap the UP button until “AUDI” is displayed, press MODE/ENTER.
3. Tap the UP button until “MASTER” is displayed, press MODE/ENTER.
4. Press EXIT to return to the main menu.

ALON Define the unit as a stand alone unit -

1. Access the main menu.
2. Tap the UP button until “NODE” is displayed, press ENTER.
3. Tap the UP button until “ALON” is displayed, press MODE/ENTER to confirm.
4. Press EXIT to return to the main menu.

RESE MAIN MENU -

ALL - When you activate the reset function, the fixture will begin the reset motion.

1. Access the main menu.

2. Tap the UP button until “RESE” is displayed, press MODE/ENTER.
3. Tap the UP button until “ALL” is displayed, press MODE/ENTER.
4. The display will show “ON/OFF”. Press the UP button to select “ON” to reset the color motor.
5. Press MODE/ENTER to confirm.
6. Press EXIT/DN to return to the main menu.

COLR - When you activate this reset function, the fixture will only reset the color wheel motor.

1. Access the main menu.
2. Tap the UP button until “RESE” is displayed, press MODE/ENTER.
3. Tap the UP button until “COLR” is displayed, press MODE/ENTER to confirm.
4. The display will show “ON/OFF”. Press the UP button to select “ON” to reset the color motor. Press MODE/ENTER to confirm.
5. Press EXIT/DN to return to the main menu.

SHTR - When you activate this reset function, the fixture will only reset the shutter/dimmer motor.

1. Access the main menu.
2. Tap the UP button until “RESE” is displayed, press MODE/ENTER.
3. Tap the UP button until “SHTR” is displayed, press MODE/ENTER to confirm.
4. The display will show “ON/OFF”. Press the UP button to

select “ON” to restart the shutter/dimmer motor. Press MODE/ENTER to confirm.

5. Press EXIT/DN to return to the main menu.

TIME MAIN MENU -

LIFE - With this function you can display the total running time of the unit.

1. Access the main menu.
2. Tap the UP button until “TIME” is displayed, press MODE/ENTER.
3. Tap the UP button until “LIFE” is displayed, press MODE/ENTER.
4. Press EXIT to return to the main menu.

LAMP - With this function you can display the running time of the lamp.

1. Access the main menu.
2. Tap the UP button until “TIME” is displayed, press MODE/ENTER.
3. Tap the UP button until “LAMP” is displayed, press MODE/ENTER.
4. Press EXIT to return to the main menu.

CLIP - With this function you can clear the running time of the lamp. **Note Very Important: Please clear the lamp time every time you replace the lamp.**

1. Access the main menu.
2. Tap the UP button until “TIME” is displayed, press MODE/ENTER.

3. Tap the UP button until “CLIP” is displayed, press MODE/ENTER.
4. Press MODE/ENTER, the display will show “ON/OFF”.
5. Press the UP button to select “ON” to activate this function, or “OFF” to deactivate this function.
6. Press MODE/ENTER to confirm.
7. Press EXIT/DN to return to the main menu.

DISP MAIN MENU -

VALU Display the DMX-512 value of each channel -

1. Access the main menu.
2. Tap the UP button until “DISP” is displayed, press MODE/ENTER.
3. Tap the UP button until “VALU” is displayed, press MODE/ENTER.
4. “VALU” should now be displayed, press MODE/ENTER.
5. The display should show “0-00”. Press the UP button in order to select the desired channel. If you select “0-05” the display will only show the DMX value of the 5th channel
6. Press MODE/ENTER to confirm.
7. Press EXIT to return to the main menu.

Now the display will change as per the 5th channel DMX value.

ON Turns the digital display on and off -

1. Access the main menu.
2. Tap the UP button until “MODE” is displayed, press MODE/

ENTER.

3. Tap the UP button until "DISP" is displayed, press MODE/ENTER.
4. Tap the UP button until "0-0N" is displayed, press MODE/ENTER.
5. The display will show "0N/0FF". Press the UP button to select "0N" to activate this function, or "0FF" to deactivate this function.
6. Press MODE/ENTER to confirm.
7. Press EXIT to return to the main menu.

FLIP - This function will reverse the display 180°.

1. Access the main menu.
2. Tap the UP button until "DISP" is displayed.
3. Press MODE/ENTER, the display will show "0N/0FF".
4. Press the UP button to select "0N" to activate this function, or "0FF" to deactivate this function.
5. Press MODE/ENTER to confirm.
6. Press EXIT to return to the main menu.

SPEC MAIN MENU -

SPOT - With this function you can adjust the lamp via the control board. The shutter opens and the lamp can be adjusted. In this mode, the device will not react to any control signal.

1. Access the main menu.
2. Tap the UP button until "RECU" is displayed, press ENTER.

3. Tap the UP button until "LADJ" is displayed, press ENTER.
4. The display will show "0N/0FF".
5. Press the UP button to select "0N" to activate this function, or "0FF" to deactivate this function.
6. Press ENTER to confirm.
7. Press EXIT/DN to return to the main menu.

DFSE - With this function you can restore the factory settings of the device. All settings will be set back to the default values. Any edited scenes will be lost. When restoring the factory settings the unit must be set to the address that the unit was in when you started editing.

1. Access the main menu.
2. Tap the UP button until "SPEC" is displayed, press MODE/ENTER.
3. Tap the UP button until "DFSE" is displayed, press MODE/ENTER.
4. The display will show "0N/0FF".
5. Press the UP button to display "0N" to activate this function, or "0FF" to deactivate this function.
6. Press MODE/ENTER to confirm.
7. Press EXIT to return to the main menu.

When you exit this function, the unit will begin to reload data.

VER - Use this function to display the Software version of the unit.

1. Access the main menu.

2. Tap the UP button until "SPEC" is displayed, press MODE/ENTER.
3. Tap the UP button until "VER" is displayed, press MODE/ENTER.
4. The display will show "V-1.0", the display may also show, "V-2.0", "V-3.9" etc.
5. Press ENTER or EXIT/DN to exit.

EDIT - This menu item allows you to write a program into the memory (EEPROM) via the control panel or via the external controller.

RUN With the function "RUN", you can run your pre-made program. You can set the number of steps under Step (S-01 - S-48). You can edit the individual scenes under Edit.

1. Access the main menu.
2. Tap the UP button until "EDIT" is displayed, press MODE/ENTER.
3. Tap the UP button until "RUN" is displayed, press MODE/ENTER.
4. "AUTO" is displayed. If you press the UP button it will show "SOLO". Select which one you want to activate, and press ENTER.
5. Press UP, to select "ALONE" or "MASTER". Which mean stand alone, and master/slave mode.
6. Select a mode, and press ENTER to confirm.
7. Press EXIT/DN to return to the main menu.

STEP - With this function you can program the number of steps in your individual Program.

1. Access the main menu.
2. Tap the UP button until "EDIT" is displayed, press ENTER.
3. Tap the UP button until "STEP" is displayed, press ENTER.
4. The display shows "S-01", this stands for the first step of your program. You can call up to 48 scenes in "Run". For example, if "S-05" is displayed, it means that "Run" will run the first

5 scenes you saved in “Edit”.

5. Press ENTER to save and exit.

SC01 - With this function you can choose the number of scenes in your Program.

1. Access the main menu.

2. Tap the UP button until “EDIT” is displayed, press MODE/ENTER.

3. Tap the UP button until “SC01” is displayed.

4. The display shows “SC01”, this stands for the first scene of your program. You can call up to 30 scenes. For example, if “SC05”, it means that “Run” will run the first 5 scenes you saved in “Edit”.

5. Press ENTER to save and exit.

Editing procedure 1: Using the control board only.

1. Access the main menu.

2. Tap the UP button until “EDIT” is displayed. Press MODE/ENTER.

3. The display will show “SC-01”, this stands for the scene number. For example, “SC-01” is displayed, it means you will be editing scene 1, press MODE/ENTER. You can change the scene number by pressing the UP button.

4. Press MODE/ENTER, the display will show “C-1”, this stands for the channel number. If “C-01” is displayed, you will be editing channel 1 of your selected scene, press MODE/ENTER. You can change the channel number by pressing the UP button.

5. The display will show the DMX value for the channel that is being edited. It will be displayed as “11XX”, it stands for Channel 11 of the editing scene, the DMX value is “XX”.

6. Adjust the DMX value by pressing the UP button, until you

get the expected effect for this channel.

7. Press MODE/ENTER to enter the editing of the other channels of the scene.

8. Repeat steps 5-8, until you finish setting all the DMX values for all the channels of this scene, each scene can have 15 channels maximum.

9. Once all the channels are completed, the display will flash “TIME”, this stands for the time needed to run this scene.

10. Press MODE/ENTER to edit the time needed, the display shows “T-XX”, “XX” stands for the time needed to run this scene. For example, “T-02” means scene 1 needs 6 seconds to run, “T-15” means this scene needs 45 seconds to run.

Note: “XX” is always three seconds not one second.

11. Adjust the time needed by pressing the UP button.

12. Press MODE/ENTER to save the settings for the scene you are editing, the display will change to the next scene automatically.

13. Repeat steps 3-12 to edit other scenes, you can edit and save 48 scenes maximum.

14. Press EXIT to exit, now you have edited and saved scenes using the control board. The number of steps can be defined under “EDIT” and the scenes can be called up under “Run”. To run the scenes see page 26.

Editing procedure 2: Using an external controller.

1. Access the main menu.

2. Tap the UP button until “EDIT” is displayed. Press MODE/ENTER.

3. The display will show “SC01”, this stands for the first scene number to be edited. For example: If “SC01” is displayed, you will be editing scene 1.

4. Change the scene number by pressing the UP button.
5. Press MODE/ENTER, the display will show “[-01”, the “1” stands for the channel number 1.
6. Press the UP button until “[EDIT” is displayed, press MODE/ENTER.
7. The display will show “OFF”, press the UP button so that “[ON” is displayed, press MODE/ENTER.
8. The display shows “[SC02”. You have successfully downloaded the first scene.
9. Adjust the Step-time. needed by pressing the UP button.
10. Call up the second scene in your controller now.
11. Repeat steps 3-6 until all desired scenes are downloaded.
12. Press EXIT to exit. The number of steps can be defined under “Step” and the scenes can be called up under “Run”.

Operating Modes: The Accu Color 250™ can operate in three different modes. This next section will detail the differences in the operating modes.

- **Stand alone mode -**

The unit will react to sound, chasing through the built-in programs.

- **Master/Slave mode -**

You can daisy chain up to 16 units together to get a synchronized light show without the need of an external controller. The units will react to sound chasing through the several built-in programs.

- **DMX control mode -**

This function will allow you to control each individual fixtures traits with a standard DMX-512 controller such as the Elation® Show Designer.™

Universal DMX Control: This function allows you to use a universal DMX-512 controller such as the Elation® DMX Operator™ or Elation® Show Designer™ to control head movement, the color wheel, gobo wheel, and the shutter (strobe). A DMX controller allows you to create unique programs tailored to your individual needs.

1. The Accu Color 250™ uses three DMX channels. Channel 1 controls color, channel 2 controls shutter/dimmer, and channel 3 controls accesses the internal programs. See page 32 for detailed description of the DMX traits.
2. To control your fixture in DMX mode, follow the set-up procedures on pages 10-14 as well as the set-up specifications that are included with your DMX controller.
3. Use the controller’s faders to control the various DMX fixture traits.
4. This will allow you to create your own programs.
5. Follow the instruction on page 16 to set the DMX address.
6. For longer cable runs (more than a 100 feet) use a terminator on the last fixture.
7. For help operating in DMX mode consult the manual included with your DMX controller.

Stand-Alone Operation (Sound Active): This mode allows a single unit or several units linked together, to run to the beat of the music.

1. Access the main menu.
2. Tap the UP button until “[RUDI” is displayed, and Press MODE/ENTER.

3. Tap UP, to select "ALON" or "NAST". Which means stand alone, or master/slave mode. Press MODE/ENTER.
4. "AUTO" is displayed. If you press the UP button it will show "SOON". Select which one you want to activate, and press MODE/ENTER.
5. Select a mode, and press MODE/ENTER to confirm.
6. Press EXIT to return to the main menu
7. The unit comes with two preprogrammed shows built-in, each show will react to low frequencies via the internal microphone.
8. You can also use the optional MINI/C Remote Control to activate the blackout function.

Master-Slave Operation (Sound Active): This function will allow you to link up to 16 units together and operate without a controller. The units will be sound activated. In Master-Slave operation one unit will act as the controlling unit and the others will react to the controlling units programs. Any unit can act as a Master or as a Slave.

1. Using standard XLR microphone cables, daisy chain your units together via the XLR connector on the rear of the units. Remember the Male XLR connector is the input and the Female XLR connector is the output. The first unit in the chain (master) will use the female XLR connector only - The last unit in the chain will use the male XLR connector only. For longer cable runs we suggest a terminator at the last fixture.
2. Tap the UP button until "AUDI" is displayed, and Press MODE/ENTER.
3. Tap UP, to select "ALON" or "NAST". Which means stand alone, or master/slave mode. Press MODE/ENTER.
4. "AUTO" is displayed. If you press the UP button it will show "SOON". Select which one you want to activate, and press MODE/ENTER.
5. Select a mode, and press MODE/ENTER to confirm.
6. Press EXIT to return to the main menu
7. You can also use the optional MINI/C Remote Control to activate the blackout function. If you want to use the optional remote control, connect the MINI/C controller to the first fixture in the line (master)

Caution: Always replace with the exact same type lamp and fuse, unless otherwise specified by an authorized American DJ® service technician. Replacing with anything other than the specified part can damage your unit and will void your manufactures warranty.

Warning: If you continue to blow lamps or fuses, STOP using the unit. Contact customer support for further instructions, you may have to return the unit for servicing. Continuing to use the unit may cause serious damage.

Lamp Replacement: Caution! Never attempt to change the lamp while the fixture is plugged in. Always disconnect the main power and allow the unit ample time to cool before attempting to replace the lamp. Lamp replacement has been made simple by incorporating a slide out lamp assembly that is retained by two phillips screws.

1. Be sure to follow the proper handling procedures that deal with discharge lamps.
2. Remove the two small screws (A,B) on the rear of the unit
3. After removing the screws, gently slide out the socket assembly from the rear of the unit to expose the lamp.
4. Carefully remove the old lamp and discard it in the trash.
5. Replace the lamp with an exact match and reassemble in reverse order.
6. After replacing the lamp follow the optimization procedures on the next page to be sure the lamp is center in the reflector

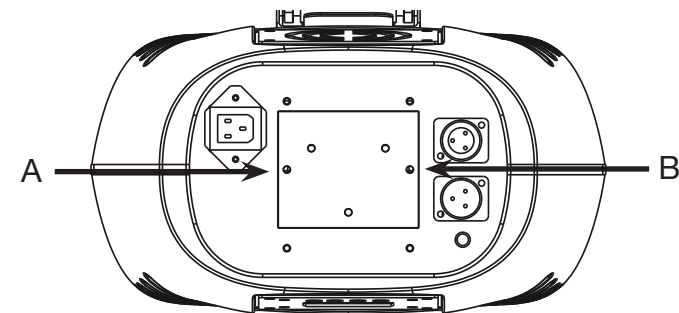

Optimizing Lamp Alignment: This procedure centers the lamp in the reflector. Proper optimization will increase lamp life and ensure a bright crisp output. Improper optimization may add a yellow tint to the lamp output and reduce intensity.

1. Be sure main power is disconnected and allow the unit to cool. If the you have just installed a new unit you can obviously skip this step.
2. Make a preliminary adjustment: Turn the three lamp adjustment thumb screws completely in (clockwise). Then back them each out (counter-clockwise) about three complete turns.
3. Turn the unit on and allow it to reset.
4. Using either a DMX controller or the control panel on the unit, strike the lamp and focus the light on a flat surface. Please see Spot on page 21.
6. Center the hot-spot (the brightest part of the beam) using the 3 adjustment screws. Turn one screw at a time to drag the hot-spot diagonally across the projected image. If you cannot detect a hot-spot, adjust the lamp until the light is even.
7. To reduce a hot-spot, pull the lamp in by turning all three screws clockwise 1/4-turn at a time until the light is evenly distributed.
8. If the light is brighter around the edge than it is in the center, or if light output is low, the lamp is too far back in the reflector. "Push" the lamp out by turning the screws.

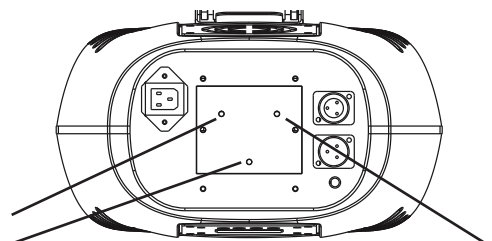

Optimizing Screws

Optimizing Screws

Fuse Replacement: Locate and remove the unit's power cord. Once the cord has been removed located the fuse holder located inside the power socket. Insert a flat-head screw driver into the power socket and gently pry out the fuse holder. Remove the bad fuse and replace with a new one. The fuse holder has a built-in socket for a spare fuse be sure not to confuse the spare fuse with active fuse.

Channel	Value	Function
1 ↓	0 - 199	<u>COLOR</u>
	0 - 21	WHITE
	22 - 43	RED
	44 - 65	BLUE
	66 - 87	GREEN
	88 - 109	YELLOW
	110 - 131	MAGENTA
	132 - 153	ORANGE
	154 - 175	PURPLE
	176 - 199	PINK
200 - 255	RAINBOW EFFECT SLOW → FAST	
2 ↓	0 - 31	<u>SHUTTER/STROBE</u>
	32 - 63	SHUTTER CLOSED
	64 - 95	DIMMER
		STROBE
		SLOW → FAST
	96 - 127	SHUTTER OPEN
	128 - 159	PULSE EFFECT
	160 - 191	SHUTTER OPEN
	192 - 223	RANDOM STROBE
	224 - 255	SLOW → FAST SHUTTER OPEN
3 ↓	<u>LAMP ON/OFF/RESET/INTERNAL PROGRAMS</u>	
	0 - 19	COLOR CHANGE NORMAL
	20 - 39	COLOR CHANGE TO ANY POSITION
	40 - 79	NO FUNCTION
	80 - 84	ALL MOTORS RESET
	85 - 87	NO FUNCTION

Accu Color 250™		DMX Traits cont.
Channel	Value	Function
3 ↓	88 - 90	COLOR MOTOR RESET
	91 - 93	NO FUNCTION
	94 - 96	SHUTTER & DIMMER MOTOR RESET
	97 - 99	NO FUNCTION
	100 - 119	INTERNAL PROGRAM 1
	120 - 139	INTERNAL PROGRAM 2
	140 - 159	INTERNAL PROGRAM 3
	160 - 179	INTERNAL PROGRAM 4
	180 - 199	INTERNAL PROGRAM 5
	200 - 219	INTERNAL PROGRAM 6
	220 - 239	INTERNAL PROGRAM 7
240 - 255	SOUND ACTIVE	

Accu Color 250™ Optional Gobo

This unit comes with an optional gobo. There is also a 30° beam angle lens (**Optional But Not Included**). Follow the instructions below to install the gobo and/or lens when desired. **Caution!** *Never open the unit when in use. Always disconnect the main power before attempting to change the gobos.*

1. To change the gobo, you must remove the top half of the unit. The top half of the unit has the LED menu on it.
2. Unscrew the four phillips screws in the top half of the unit. Remove the top half of the unit.
3. When you remove the top half you will be able to see four thumb screws. See the picture below for reference.

Optional 30° beam angle lens screws in here

Optional Gobo holder screws in here

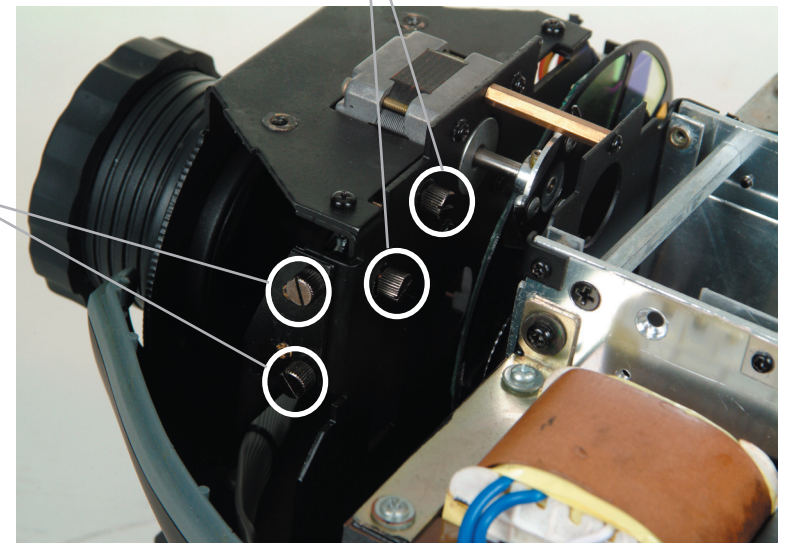

Fixture Cleaning: Due to fog residue, smoke, and dust cleaning the internal and external optical lenses and mirror should be carried out periodically to optimize light output. Cleaning frequency depends on the environment in which the fixture operates (i.e. smoke, fog residue, dust, dew). In heavy club use we recommend cleaning on a monthly basis. Periodic cleaning will ensure longevity, and crisp output.

1. Use normal glass cleaner and a soft cloth to wipe down the outside casing.
2. Use a brush to wipe down the cooling vents and fan grill.
3. Clean the external optics and mirror with glass cleaner and a soft cloth every 20 days.
4. Clean the internal optics with glass cleaner and a soft cloth every 30-60 days.
5. Always be sure to dry all parts completely before plugging the unit back in.

Trouble Shooting: Listed below are a few common problems that you may encounter, with solutions.

No light output from the unit;

1. Be sure you have connected your unit into a standard 120v wall outlet.
2. Be sure the external fuse has not blown. The fuse is located on the bottom panel of the unit.
3. Remove the lamp holder and be sure the lamp is seated in its socket properly. Occasionally lamps become loose during shipping be sure the lamp is push in to its socket all the way.
4. Be sure the fuse holder is completely and properly seated.

Unit does not respond to sound;

1. Low frequencies (bass) should cause the unit to react to sound. Tapping on the microphone, quiet or high pitched sounds may not activate the unit.

1-YEAR LIMITED WARRANTY

A. American DJ® hereby warrants, to the original purchaser, American DJ® products to be free of manufacturing defects in material and workmanship for a period of 1 Year (365 days) from the date of purchase. This warranty shall be valid only if the product is purchased within the United States of America, including possessions and territories. It is the owner's responsibility to establish the date and place of purchase by acceptable evidence, at the time service is sought.

B. For warranty service, send the product only to the American DJ® factory. All shipping charges must be pre-paid. If the requested repairs or service (including parts replacement) are within the terms of this warranty, American DJ® will pay return shipping charges only to a designated point within the United States. If the entire instrument is sent, it must be shipped in its original package. No accessories should be shipped with the product. If any accessories are shipped with the product, American DJ® shall have no liability whatsoever for loss of or damage to any such accessories, nor for the safe return thereof.

C. This warranty is void if the serial number has been altered or removed; if the product is modified in any manner which American DJ® concludes, after inspection, affects the reliability of the product; if the product has been repaired or serviced by anyone other than the American DJ® factory unless prior written authorization was issued to purchaser by American DJ®; if the product is damaged because not properly maintained as set forth in the instruction manual.

D. This is not a service contract, and this warranty does not include maintenance, cleaning or periodic check-up. During the period specified above, American DJ® will replace defective parts at its expense, and will absorb all expenses for warranty service and repair labor by reason of defects in material or workmanship. The sole responsibility of American DJ® under this warranty shall be limited to the repair of the product, or replacement thereof, including parts, at the sole discretion of American DJ®. All products covered by this warranty were manufactured after January 1, 1990, and bear identifying marks to that effect.

E. American DJ® reserves the right to make changes in design and/or improvements upon its products without any obligation to include these changes in any products theretofore manufactured.

F. No warranty, whether expressed or implied, is given or made with respect to any accessory supplied with products described above. Except to the extent prohibited by applicable law, all implied warranties made by American DJ® in connection with this product, including warranties of merchantability or fitness, are limited in duration to the warranty period set forth above. And no warranties, whether expressed or implied, including warranties of merchantability or fitness, shall apply to this product after said period has expired. The consumer's and or Dealer's sole remedy shall be such repair or replacement as is expressly provided above; and under no circumstances shall American DJ® be liable for any loss or damage, direct or consequential, arising out of the use of, or inability to use, this product.

G. This warranty is the only written warranty applicable to American DJ® Products and supersedes all prior warranties and written descriptions of warranty terms and conditions heretofore published.

H. Lamps are not covered under this or any other warranty, either written or implied.

Model:	Accu Color 250™
Voltage*:	120v/60Hz or 230v/50Hz
Lamp:	ZB-MSD250/2 250w 2000 Hours
Dimensions:	14.5”(L) x 9”(W) x 11.5”(H) 355mm x 228mm x 292mm
Colors:	8 Plus White
Gobos:	1 Static Gobo (optional and included) 26.2mm Outside/ 25.5mm Viewable
Weight:	26.5 Lbs. / 12 kgs.
Fuse:	8A (120v) / 4A (220v)
Duty Cycle:	None
DMX:	3 Channels
Sound Active:	Yes
Working Position:	Any Safe, Secure Position
Warranty:	1 Year (365 days)

*Voltage is preset at the factory and is not user selectable

Please Note: Specifications and improvements in the design of this unit and this manual are subject to change without any prior written notice.